

VARIABLE CONTROL

Leading edge dimmer for LED lighting or motor speed control

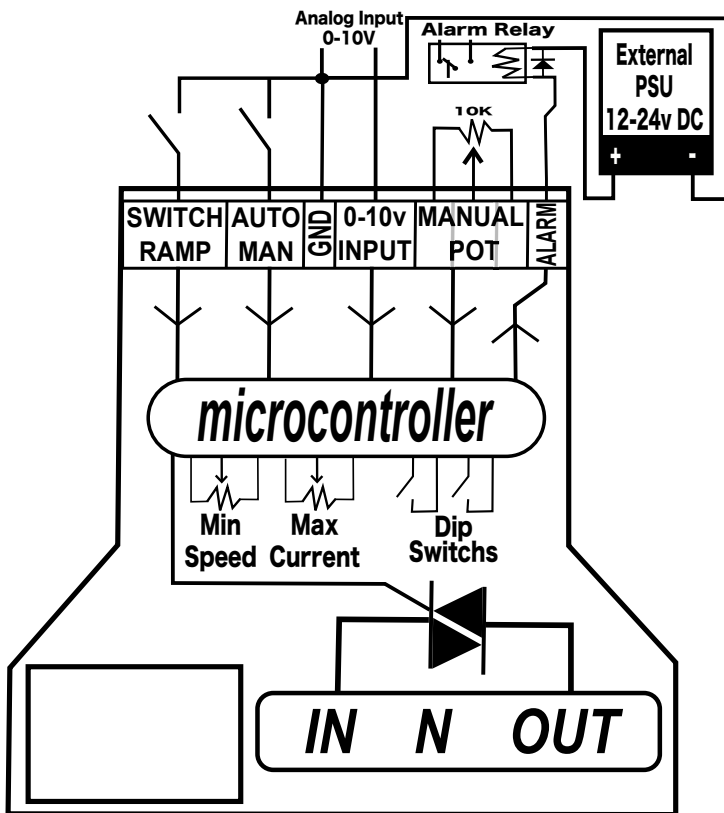

Installation:

230v Input should be protected with an adequate fuse or MCB.

The din rail must be connected to the supply earth.

Dip switches on the board must be set before power is applied

The min speed pot on the PCB will set the min voltage that it can drop to. (up to 50%)

The max current pot on the PCB will set the max current draw from the output. (max of 20A)

Setting dip switches & operations:

1=ON 2=OFF Switch mode:

When “switch ramp” is made the output will be set to the “manual pot”.

1=OFF 2=ON 0-10v mode:

The output is linear to the 0-10v input, min speed 0% to 100% (calibration of the 0-10v will be needed)

1=OFF 2=OFF Ramp mode:

When the “switch ramp” is made the output will be ramped from the min speed up to 100% over the next 15mins (the max brightness can be adjusted see below how to adjust).

1=ON 2=ON Not used.

When the “auto man” is made it will be in a manual state and the output will be linear to the “manual pot” input. (10k)

Push set button to view the set min speed and the max current and adjust accordingly using the two small pots on the PCB.

Setting for motor or lighting control:

The default is used with lighting, on power up at the bottom of the display it will say "Lighting Control" or "Motor Control" to adjust push and hold the set button on power up and release when the welcome screen has displayed.

Setting up the 0-10v input:

Push and hold the set button to enter the setup mode, set the "0-10v input" to its minimum speed / brightness and then press set, then set the "0-10v input" to its maximum speed / brightens and then press set.

Setting the max brightness:

Push and hold the set button to enter the setup mode, rotate the manual pot to set the max brightness and then push set.

Potential alarms:

Overload when the output has pulled more than the maximum set current, use the small pot on the PCB to adjust accordantly.

Over Temp When the classic temperature has risen above 65 degrees the unit will switch the output off the protect itself.

If an over temperature becomes a problem an fan kit is available, it is recommended for higher loads.

To reset after an alarm has occurred turn the unit off for a few seconds and re-power.

Alarm output:

The alarm output has an max output of 300mA and switches on the GND, a diode will be needed across any inductive loads such as a relay coil, see diagram above.

if this is only being used for an indicator (LED) use the alarm and the pin 1 of the manual pot and this will give you a switched 5v output.

WARNING THERE IS 230V EXPOSED COMPONENTS ON THIS PCB AND SHOULD BE INSTALLED / MAINTAINED BY AN COMPETENT PERSON.

If the alarm output is used in part of an alarm loop regular testing will be required to guarantee operation