

Installation & User Manual



www.vale-systems.co.uk



VICTRON 10

*The
Dynamic
Environmental Controller*

3.2v

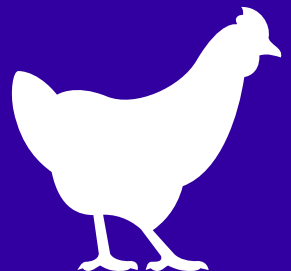

Contents

		Page
Installation		
1	Safety instructions & warnings.....	2-3
2	Technical specifications.....	4
3	Circuit diagrams	
	3.1 Analog outputs.....	5
	3.2 Digital sensors.....	6
	3.3 Digital inputs.....	7
	3.4 Data & alarm output.....	8
	3.5 Relay outputs.....	9
	3.6 I/O layout.....	10
	3.7 Relay layout.....	11-12
4	Setting of I/O & testing.....	13
User Manual		
5	Main display.....	15
6	Ventilation	
	6.1 Ventilation Overview.....	16
	6.2 Ventilation Minimum vent.....	17
	6.3 Ventilation Over temp.....	18-19
	6.4 Ventilation Treatments.....	20
	6.5 Ventilation Settings.....	21
	6.6 Ventilation Speed fans.....	22
	6.7 Ventilation Live weight.....	23
	6.8 Ventilation Min vent block.....	24
7	Heating	
	7.1 Heating.....	25
	7.2 Heating treatments & boost.....	26
8	Cooling	
	8.1 Cooling.....	27
9	Lighting	
	9.1 Lighting & Curtains.....	28
10	Feeding	
	10.1 Feed clock.....	29
	10.2 Feed shut down.....	30
	10.3 Feed Blend.....	31
11	Water	
	11.1 Drinker flushing.....	32

Contents

13	Extra outputs	
	13.1 Extra.....	33
14	History	
	14.1 Mortality.....	34
	14.2 General History.....	35
15	Recirculation Fans	
	15.1 Stir fans.....	36
16	Configuration & setup	
	16.1 Configure Setup.....	37
	16.2 Configure Table Setting.....	38
	16.3 Alarms.....	39
	16.4 Saving & Reading to USB	40
	16.5 Testing I/O.....	41
	16.6 Setting I/O.....	42
	16.7 Net (remote access).....	43-44
	Notes.....	45



1 Instructions & warnings

This manual contains all necessary information to connect, adjust and operate the product. Carefully read the instructions before installation.

The installation, which forms an integral part of the product, must be executed by professional installers, following the prevailing standardisation.

If the product is mounted into a panel not supplied by Vale Systems, the guarantee will be voided. The configuration, in which this product is incorporated, must be provided with a sound alarm device that needs to be checked on its proper operation at intervals (at least once a day).

If the product is an integral part of a climate controlling system, we draw your attention to the fact that sufficient oxygen content in the room to be controlled should be permanently guaranteed, even in situations of emergency. To guarantee the adequate level of oxygen we recommend the installation of an emergency device that is to be checked on its proper operation at intervals.

An emergency device may consist of:

- a manual operation facility;
- emergency opening systems;
- a stand-by unit.

1 Instructions & warnings

Further we point out the following:

- The computer is an electronic device, therefore always take into account that a disturbance or malfunction can occur.
- It is necessary to connect the alarm contacts of several computers on a central alarm unit.
Vale Systems suggests installing an extra independent alarm device (for example: a min/max thermostat).
- Vale Systems has taken all effective measures possible to ensure that an alarm is given during any failure. Unfortunately, this cannot be 100% guaranteed.
- Do not use running water to clean your computer. The computer is water resistant, not waterproof!
- The Victron is under no circumstances a safety component.
- The Victron may only be operated and adjusted by people who are familiar with the operating instructions provided in this manual.

Electrical	: IP21	
Supply voltage	: 230Vac 50Hz +/-10%	
Power consumption	: Max 500mA	
Main protective fuse	: 1A	
Digital inputs		
Counters	: NPN/PNP 12Vdc 8mA max	
Temp / combo sensors	: To be wired in screened cable (3core) and a max distance of 150 meters	
Analog outputs		
0-10v	: 0-10v max 10mA	
Analog Inputs		
0-5v	: 0-5v max 10mA	
Digital outputs		
Relay outputs	: 1.0A 50Vdc / Vac	
Alarm output	: 0.4A 24Vdc / Vac	
Communication		
RS485	: max 500m @ 100kbs	
Power outputs		
12v out	: 12Vdc max 0.5A to be protective by an adequate fuse	
Sensors		
Temperature sensors	: 1°C to +50°C	±0.35°C
Combo sensor	: RH 20-80%	±2%,
	: CO2 400-5000ppm	±3%
Static pressure sensor	: -125-125Pa	±3%

3.1 Circuit diagram

Analog outputs:

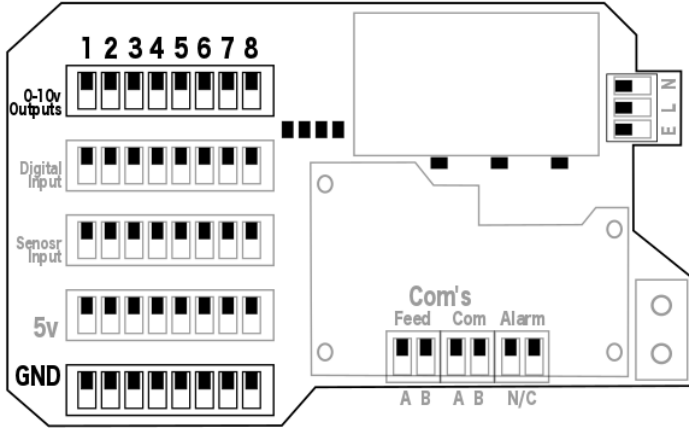

The analog outputs are freely programmable and have a range of 0-10Vdc output (max 10mA),

The standard configuration is:

- 1 inlet 1 (side or rich)
- 2 inlet 2 (tunnel)
- 3 lights
- 4 windows

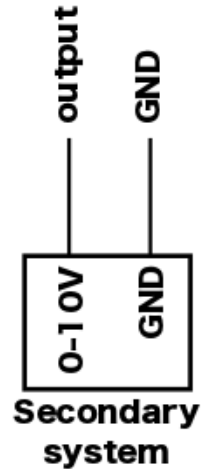

3.2 Circuit diagram

Digital sensors:

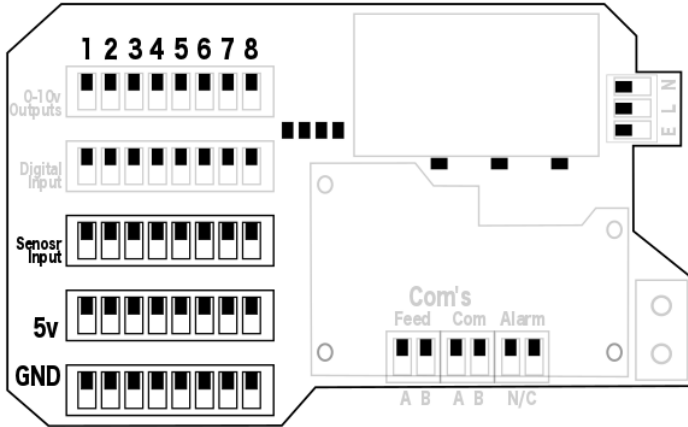

The digital sensor inputs are freely programmable and are to be used for temp sensors, combo sensor and chick scales, should all be wired in screened cable (CY) and not to exceed the max length of 120 meters and the max size of 0.75mm², all screens should be grounded to GND at one end, all power outputs are short circuit protected, all cores should be connected.

The standard configuration is:

- 1 Temp sensor 1
- 2 Temp sensor 2
- 3 Temp sensor 3
- 4 Temp sensor 4
- 5 Temp sensor 5
- 6 Temp sensor 6
- 7 Outside sensor (Only needed on one controller per site)
- 8 Combo sensors (Use the 5v high current output from 7 or 8)

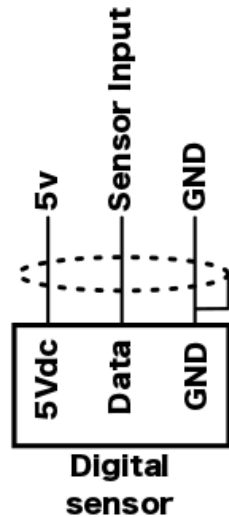

3.3 Circuit diagram

Digital inputs:

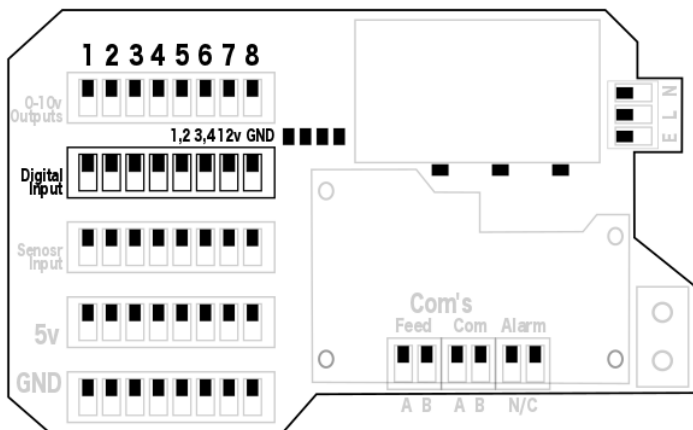

The digital inputs are freely programmable and are pulse inputs and are to be used for water, gas and electric (Kwh) meters, all should be wired in screened cable (CY) and all screens should be grounded to GND at one end.

Different pulses can be set in the setup page.

The standard configuration is:

- 1 Water meter
- 2 Gas meter
- 3 Electric meter
- 4 Aux alarm input

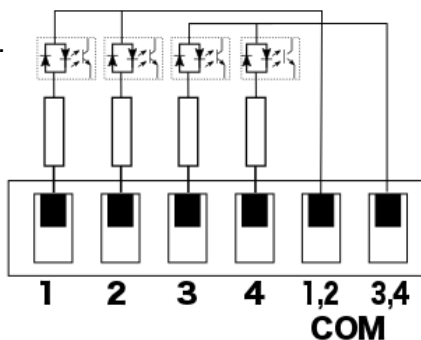

See internal connections:

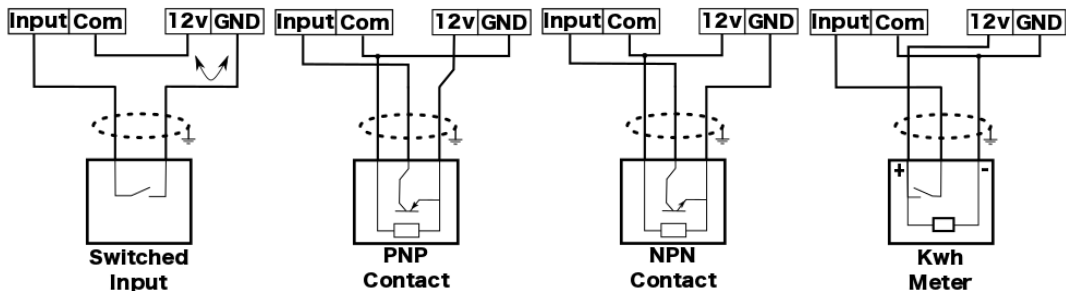

3.4 Circuit diagram

Data & alarm output:

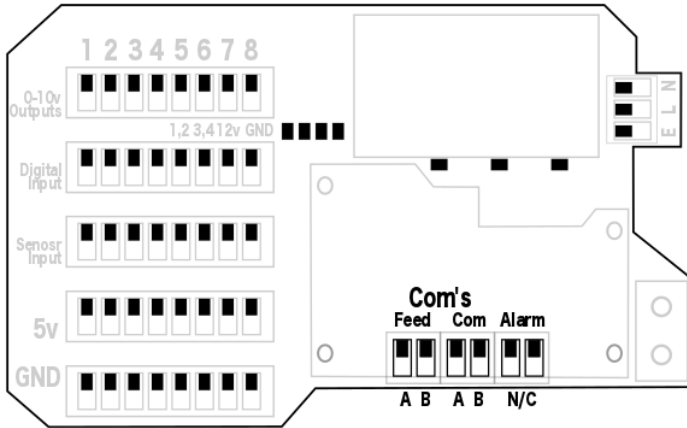

Feed:

The RS485 Local bus provides communication between the Victron board and the Feed Control.

COM: This output has no function.

RS485 cable must be a twisted pair of AWG 18 (0.82mm²), max 500 meter in length, keeping the stripped length to a minimum.

Alarm:

The output is volt free and is broken during an alarm.

0.4A 24Vdc max

Ethernet / USB:

On the pcb under the motherboard there is an ethernet RJ45 and a usb, for more information on using the usb go to page 38, the RJ45 is used as a communication between the Victron (for sharing the external sensor inputs so only one out side sensor will be needed) and the Could (Victron Manager) and CCTV, a switch can be supplied to give the Victron more outputs, no cable to be long than 70m between Victons, for more information see page 42.

3.5 Circuit diagram

Relay outputs:

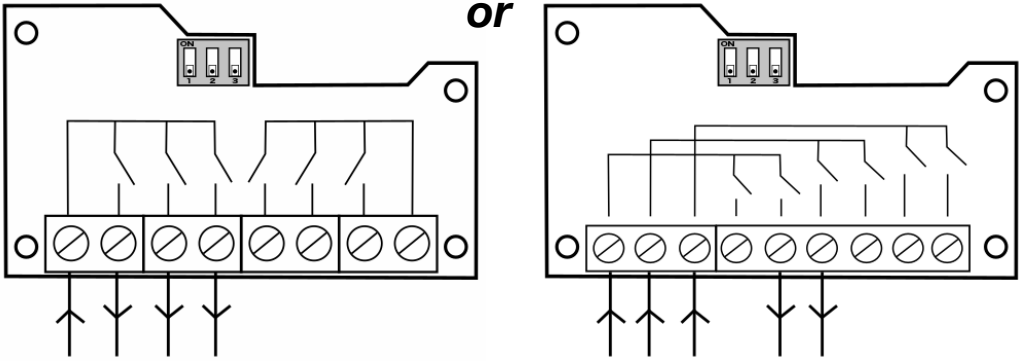

The outputs must not exceed 2.0A 50Vdc / Vac

This outputs are not for inlet motors.

The relay cards can be stacked but each card needs to know where it is in the stack, using the dip-switches to select where it is.

Use the table below for setting of the dip-switches.

Board	Sw1	Sw2	Sw3
Board 0	OFF	OFF	OFF
Board 1	ON	OFF	OFF
Board 2	OFF	ON	OFF
Board 3	ON	ON	OFF
Board 4	OFF	OFF	ON
Board 5	ON	OFF	ON
Board 6	OFF	ON	ON
Board 7	ON	ON	ON

3.6 Circuit diagram

I/O layout:

Analog Output 1	Inlet 1 (Side Inlets)
Analog Output 2	Inlet 2 (Tunnel Inlets)
Analog Output 3	Lights
Analog Output 4	Windows
Analog Output 5	Heating valve
Analog Output 6	Recirc 1
Analog Output 7	Recirc 2
Analog Output 8	
Digital Sensor 1	Temp 1
Digital Sensor 2	Temp 2
Digital Sensor 3	Temp 3
Digital Sensor 4	Temp 4
Digital Sensor 5	Temp 5
Digital Sensor 6	Temp 6
Digital Sensor 7	Outside Temp and RH sensor
Digital Sensor 8	Combo sensor
Digital Input 1	Water meter
Digital Input 2	Gas meter
Digital Input 3	Kwh meter
Digital Input 4	Aux Alarm input (N,O)

Use the following table to document the I/O to show their connection.

3.7 Circuit diagram

Relay layout:

Relay	1	Fan stage 1
Relay	2	Fan stage 2
Relay	3	Fan stage 3
Relay	4	Fan stage 4
Relay	5	Fan stage 5
Relay	6	Fan stage 6
Relay	7	Fan stage 7
Relay	8	Primary heating 1
Relay	9	Primary heating 2
Relay	10	Primary heating 3
Relay	11	Secondary heating 1
Relay	12	Secondary heating 2
Relay	13	Llghting
Relay	14	Cross auger
Relay	15	Pans
Relay	16	
Relay	17	
Relay	18	
Relay	19	
Relay	20	
Relay	21	
Relay	22	
Relay	23	
Relay	24	

3.7 Circuit diagram

Relay	25	
Relay	26	
Relay	27	
Relay	28	
Relay	29	
Relay	30	
Relay	31	
Relay	32	
Relay	33	
Relay	36	
Relay	37	
Relay	38	
Relay	39	
Relay	40	
Relay	41	
Relay	42	
Relay	43	
Relay	44	
Relay	45	
Relay	46	
Relay	47	
Relay	48	

Use the following table to document the relays output to show their connection.

4 Setting the I/O & testing

Setting the I/O:

Once the Victron has been connected according to the circuit diagrams. Pressing “Setup” will enter you into all the Victron settings.

This is where you specify all the I/Os, use the table on page 10/12 to help to set all the I/Os

For more information look at pages 38 and 39.



4.1 Testing:

Allows you to manually turn output on, off and into automatic, when leaving this page all settings will return back to auto.

After setup it is possible to save all setting to USB and retrieve on the next installation, for more information look at page 37.

4.2 Configure:

Allows you to adjust, set temp, house mode, grow day, house number, set time and data.

Set Temp: The set temp for the house.

Empty house: will stop the operation of the Victron.



5 Main display

The home page, this screen shows a total overview of the actual process status and of all the equipment controlled by the Victron computer.

Displaying of any alarm

This bar will move up and down depending on ventilation temp

The point that the primary will switch on at.

The point that the secondary will switch on at.

House temp sensors

Index can be in C or F

This will be coming from the bird weiger if used or if not it will be predicted

If feed blending is being used: blend %

Consumption of each silo

Current silo wight

Displaying of any alarm

This correspond to where they are in the vent page

If any cooling output are triggered

Calculated air flow

The fans that are on

Opposition of inlets

If clicking on any of these boxes it will switch to the last 3 day of history. (Quick veiw)

Is the feeding on or off..

Has the feed shut down been activate

Menu:

- Ventilation
- Lighting
- Extra
- Configure
- Setup
- Heating
- Air Fans
- Feeding
- History
- Alarms
- Cooling
- Blender
- Water
- Test
- House Number

At the bottom of the page is a menu of sub setting.

To return back from sub setting page push the home logo at the top right of the page.

6.1 Ventilation Overview

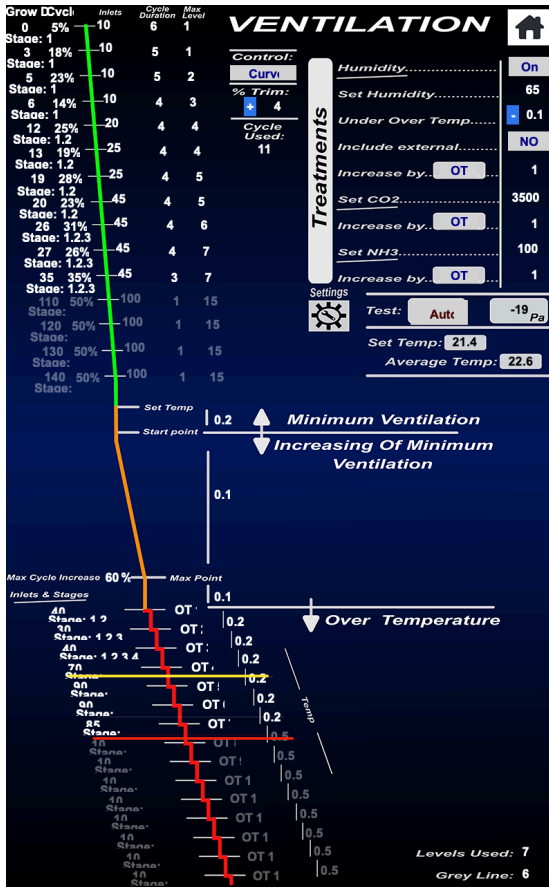

- The Victron can control up to:
 - 14 fan groups (on/off)
 - 4 methods of 0-10v air inlets (eg side and/or tunnel)
 - 4 variable 0-10v fans groups
 - 4 0-10v fan flaps groups

The main ventilation table shown above is where the desired ventilation is set for each point, using the control button in the centre of the page will toggle the min vent table for curve to live weight but for now we will look at the curve table as shown.

Table with green line is the min vent table and shows the grow day of that line, stage that will be used, cycle on time in %, inlets on position in % (the table shown is only displaying one inlet but up to 4 can be displayed), cycles duration of the on and off time in minutes and the max level for the table at the bottom, you can see there is a red line to show where it is currently set at, this will stop the ventilation going over this point.

6.2 Ventilation Minimum Vent

The yellow line is to show where you are currently in the table.

To set how much of the table is being used adjust the cycle used in the centre of the page above, if needed one can be set to keep a fixed min vent settings.

If a trim is needed to pull all of the cycle % up or down use the “% trim” in the centre of the page above.

If clicking on one of the lines a box will pop up, see below.

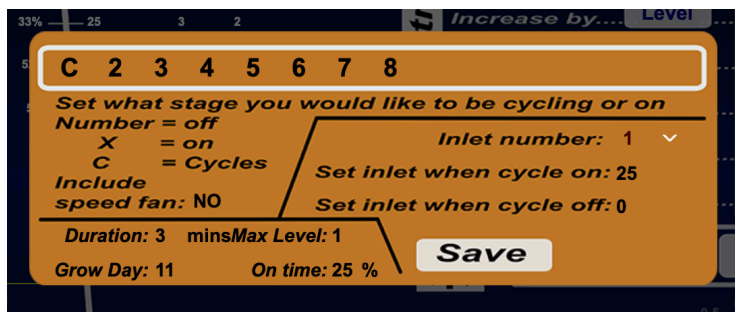

Here you can set all of the setting of that line as mentioned above, pushing on the number at the top of the page will toggle between X and C, the X is that stage which will be on all the time and C will cycle that stage on and off depending on the set duration and the on time %.

After choosing the inlet number from the drop down it is possible to set an on and off position, this is for when a cycle is being used, if a cycle is not being used it is recommended the set “on %” to 100%.

Duration: the total time of the cycle in minutes

Max Level: the max level for the table at the bottom (red)

Grow Day: as it implies

On Time: The on % out of the duration time

Push save to return back.

The Victron will not jump between each line it will move linearly between them.

6.3 Ventilation Over Temp

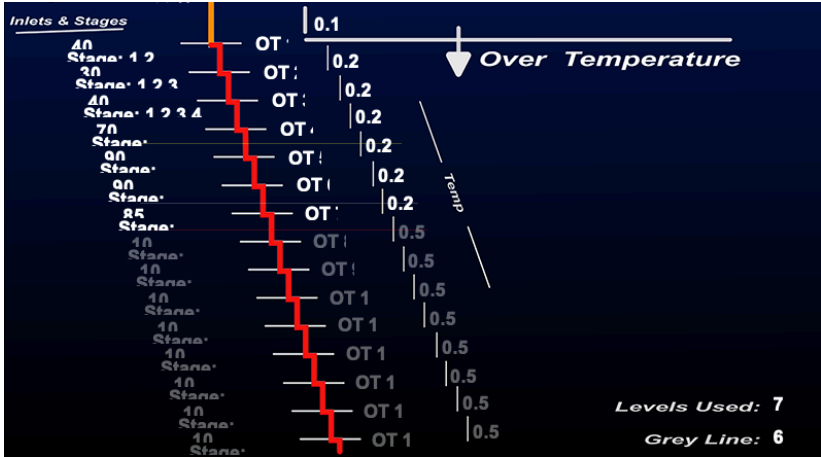

Under temp up to OT1:

The over temp table at the bottom of the ventilation page (red) shown above, as you can see there is a orange line from the min vent table down to the over temp table, so what ever is set in the min vent table is been used under the set temp and up to the “start point”, from there to the “max point” the cycle % will be increased over the increased temp to “max cycle” that is in % on top of what is coming from the min vent table (eg if we have 10% coming from min vent table and the “max cycle increase” is set to 90% at the “max point” it will be 100%) after that we have a dead band and moving from there into the OT1, all of the number that are shown are adjustable by clicking on them.

OT1 & onwards: (same concept as the top of the table, green)

	X X X 4 5 6 7 8						
Set what stage you would like to be cycling or on							
Number = off							
X = on							
C = Cycles							
Include speed fan: NO				Inlet number: 1 ▾			
Duration: 1 mins				Set inlet when cycle on: 55			
On time: 100%				Set inlet when cycle off: 55			
Save							

6.3 Ventilation Over Temp

The pop up works in the same way as the one for the min vent table, here you can set all of the setting of that OT., pushing on the number at the top will toggle between the number, X and C, the X of that stage will be on all the time and C will cycle that stage on and off depending on the set duration and the on time %.

After choosing the inlet number from the drop down it is possible to set an on and off position, this is for when a cycle is being used, if a cycle is not being used it is recommended the set the “on %” to 100%.

Duration: the total time of the cycle in minutes

Max Level: the max level for the table at the bottom

Grow Day: as it implies

On Time: The on % out of the duration time

Push save to return back.

To stop the house over venting it is possible to set a max level, see page 6.2.

6.4 Ventilation Treatments

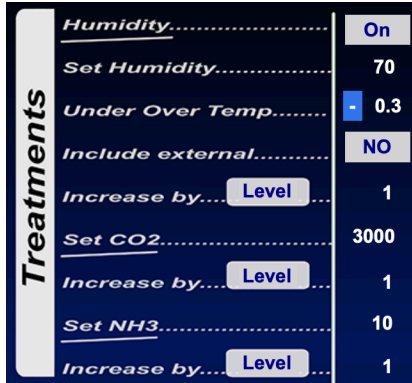

- Humidity: A button to switch the humidity treatment on, off and curve, this can be set in the configure page.
- Set humidity: The set point that you would like the treatment to start.
- Under over temp: Depending if set to + or - of the set temp will stop the treatment if the house is getting to cold.
- Include external: if you have an outside weather station and this is set to yes it will only allow the treatment if the outside humidity is better than what is set.
- Increase by: this is where we set what is going to happen if all of the above it meet, can increase using % or/and OT.. this will add this amount onto all % and all OT.. this will push up to the next OT.
- Set CO2 / NH3: The set point that you would like the treatment to start.

It is possible to manually bring on any min vent or OT for testing, this is helpful for determining the correct inlet position, it also shows the house pressure.



6.5 Ventilation Settings

Ventilation

VENT SETTINGS

Speed Fan vs Fan Valve Inlet

Fan %	1	2	3	4
0	0	0	0	0
20	20	20	20	20
40	40	40	40	40
60	60	60	60	60
100	100	100	100	100

Outside temp Correction

Temp	Cycle %	Inlet Vent %
1.0	0	0
2.0	0	0
3.0	0	0
4.0	0	0

Delaying the inlet vents before or after a change of position

Increase Vent 1.....	3	Decrease Vent 1...	1
Increase Vent 2.....	3	Decrease Vent 2...	1
Increase Vent 3.....	3	Decrease Vent 3...	1
Increase Vent 4.....	3	Decrease Vent 4...	1

Sensors

Used:	1	2	3	4	5	6
	X	X	X	X	X	X

MIN VENT BLOCK

*You MUST understand before use...
Refer to user manual*

On/Off.....	ON
If under set grow day.....	7
If under this amount Over the set temp.....	0.3
If under set RH.....	55
If under set Co2.....	500
If under set NH3.....	2
If under set outside temp.....	18.0
Max amount of cycles skipped..	2

*To be active:
 If set to on, grow day and over temp are met and under the set RH, Co2, NH3 and outside temp.
 If the above is met when the min vent on cycle will be missed, this can only occur if the max amount of cycle skipped set.*

“Speed fan vs fan valve” is the relation of the fan speed in % to the % of the valve inlet, for more about speed fan see page 6.6.

“Outside temp correction” is used to decrease the min vent % as the outside temp falls and the inlet vent decrease the inlet as the outside temp falls to pick up air speed.

“Delay of the inlet before or after a change” has been made, delay time between the fan on/off state change and that inlet vents changing. A negative value means the inlet vents will change before the fan on/off stage change. A negative value means the fan stage on/off will change before the inlet vent changes.

“Sensor” shows witch sensors are being used for the ventilation.

“Min vent block” see page 6.8.

21

6.6 Ventilation Speed Fans

C 2 3 4 5 6 7 8 9 10

Set what stage you would like to be cycling or on

Number = off
X = on
C = Cycles

Include
speed fan: NO

Duration: 6 mins Max Level: 1
Grow Day: 0 On time: 5 %

Inlet number: 1
Set inlet when cycle on: 10
Set inlet when cycle off: 0
Speed max inlet:

Save

It is possible to use speed control fans for min vent and or over temp.

On the yellow pop up page there is a button “Speed fan inlet” the speed will be set in %,

This applies to min vent table and the over temp table.

This can also be used in conjunction with any heat exchanger.

6.7 Ventilation Live Weight

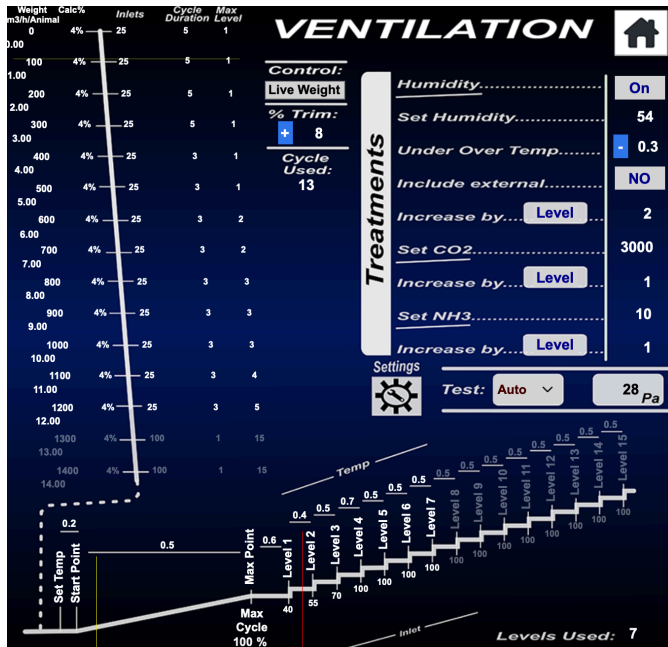

If toggling the control button to live weight the table on the left will change over, click on one of the rows to input the weight and m3h / animal and it will come up with the calculated min % needed for that weight, for this to work correctly it will need an accurate bird weight (to be inputted or use a Victron bird scale) and the correct fan capacity.

The trim will allow the % to be trimmed up or down.

For over temp it works in the same way as documented in 6.3.

6.8 Ventilation Min vent block

MIN VENT BLOCK
*You MUST understand before use...
Refer to user manual*

On/Off.....	ON
If under set grow day.....	7
If under this amount Over the set temp.....	0.3
If under set RH.....	55
If under set Co2.....	500
If under set NH3.....	2
If under set outside temp.....	18.0
Max amount of cycles skipped..	2

*To be active:
If set to on, grow day and over temp are met and under the
set RH, Co2, NH3 and outside temp.
If the above is met when the min vent on cycle will be missed,
this can only occur if the max amount of cycle skipped set.*

If using min vent block control care must be taken when using to insure that the stock are not starve from air.

If under the set grow day, under the set over temp, under the set RH, Co2, NH3 and under the set outside temp the vent block will become active and will stop the on time of your cycle timers when all of the above are met but this can only occur the max amount of cycles skipped that have been set.

When this occurs on the home page the min vent % will change to yellow to show that a cycle is being skipped.

This would typically be used for the first week only..

7.1 Heating

HEATING

Zone	Temp Allocation	On Set	Off Set	RH	Min	Max
Primary						
1	X	0.4	0.1	X	10	10
2	X	0.4	0.1	X	10	10
3	X	0.4	0.0		10	10
4	X	0.4	0.0		10	10
Secondary						
1	X	1.2	0.5	X	10	10
2	X	1.2	0.5	X	10	10
3	X	0.8	0.1		10	10
4	X	0.8	0.1		10	10
Variable						
1	X	1.0	0.1	0	0	100
2	X	1.0	0.1	0	0	100
3	X	1.0	0.1	0	0	100
4	X	1.0	0.1	0	0	100

RH Control **Set** **Set RH:** 60

Over Temp: 0.3 **Duration Time:** 1 **On Time:** 50.0

Stop all heating: **OT1**

Secondary heat boost: 180

STIR FANS

	Temp Allocation	Diff Low	Diff High	Min Speed	Max Speed	Lev Off
Near	X	0.3	1.0	90	100	OT1
Far	X	2	2	0	100	

The heating can control 4 primary, 4 secondary heating outputs and 4 variable 0-10v outputs, select any combination of temp sensor per heating zones, able to select any on & off point for each zone and a min/max run time, humidity treatments for any zone and a boost function to boost the heating in the house when struggling to maintain the required temperature.

- Zone : The heating outputs.
- Temp Allocation : Select any combination of sensors for any zone.
- On set : how much below the set temp that the heating will come on at, or the max variable output.
- Off set : how much above or below the set temp that the heating will turn off at, or the min variable output, using the button that toggle between + / - set the off set below the set temp or above.
- RH : X = that zone will be used for humidity treatment, variable outputs can set as a %.

7.2 Heating treatments & boost

Humidity control:

The treatment will only take affect on the zone with “X” in RH menu.

Treatment RH : Toggle the treatment on & off or curve if using curve the valve comes for the config table, see page 16.1.

Set RH : The set point of treatment.

Duration time : The full duration of the cycle (on and off) in mins.

On time : This is the set on time in a percentage.

Over temp : Over temp is a safety feature to stop the treatment when the house temperate rise over the set point, e.g 0 would stop at set temp.

percentage calculation example:

We have a 20 min duration and we desired 3 min of that is on what is the percentage...

$$100 \times 3\text{min} = 300$$

$$300 / 20\text{min} = 15\%$$

Secondary heat boost:

If the primary heating has been running for a period of time and has not reached the desired temperature the secondary heating will come in and boost it up to the primary set point. (min)

Stop all heating:

In the drop down it is possible to choose “any” if any stage comes on all the heating outputs will be switched off for the time the stage is on for, or choosing a level of ventilation when the ventilation exceeds this point all heating will be switched off.

Stir Fans:

See page 15.1.

8.1 Cooling



COOLING

Zone	Temp Allocation	Start Set Temp	Max Set Temp	RH Stop	Duration Sec	Min %	Max%	
PWM	1	X X X . . .	3.0	5.0	55	60	17	100
	2	1.0	5.0	50	60	10	100
	3	1.0	5.0	50	60	10	100
	4	1.0	5.0	50	60	10	100
Variable	1	1.0	5.0	50		10	100
	2	1.0	5.0	50		10	100
	3	1.0	5.0	50		10	100
	4	1.0	5.0	50		10	100

Start Time: 11:00 End Time: 16:00 Control: OFF

Manual Wetting / Cleaning Control

	Minutes	Sec	Sec
Run Time:	15	Pulse Time On: 30	Pulse Time Off: 30
Cleaning Flush Time:	15	Pulse Time On: 30	Pulse Time Off: 30

Trigger: OFF

The cooling has 4 outputs that can be used as PWM and 4 variable output (0-10v), select any combination of temp sensor per cooling zone, start temp is the lowest PWM or the min of the variables and the max temp is the highest PWM or the max variables and moves linearly between the to, the min/ max% are the PWM or variable in %, the duration this the total on and off time in sec, if the RH is over the set RH that zone will be switch off, the cooling will only function when with in the start / end times.

The control button toggle between auto (top table) and the manual (bottom table).

The manual wetting is used as a manual feature, it is possible to set a run time and a PWM with in that time and after that has elapse it will move onto cleaning flush with work in the same way as before, if an flush valve is used this will be triggered for this time.

A pump output can be set that will be active when any cooling is on.

9.1 Lighting & Curtains

LIGHTING					
<i>Day</i>	<i>Off Time</i>	<i>Duration</i>	<i>1 Min 2</i>	<i>1 Max 2</i>	

The lighting / Curtains can use up to 25 periods, and multiple periods can have the same grow day.

- Day : The grow day
- Off time : This is the time that the lights will be off or at the min brightness.
- Duration : This is the length of time that the lights will be off for or at the min brightness.
- Min light : The minimum light level for that period.
- Max light : The maximum light level for that period.
- 1 / 2 : Will allow different brightnesses for either outputs if more then one output is being used.

Curve points used: 2 Ramp on time: 15 Ramp off time: 15

- Curve points used : How many lines used in the main table above
- Ramp on time : The time it takes to transition from min to max.
- Ramp off time : The time it takes to transition from max to min.

Same all apply for the curtain control.

10.1 Feed Clock

FEEDING							
Grow Day	Feed Clock		Repeat Off Time	Min Alarm	Max Alarm		
	On Time	Duration					
0	12 00	00 15	<input checked="" type="checkbox"/>	06 00	0	3000	
6	12 00	00 15	<input checked="" type="checkbox"/>	06 00	0	3000	

Feed Clock used for the feeding system with-in the house, pans and cross auger, when switching on, both will be active, and when switching off, pans will switch off, and after 5mins the cross auger will switch off, this will allow the auger to catch up if needed.

Multiple periods can have the same grow day.

Can use up to 25 periods of feeding.

Day : The grow day

On time : This is the time that the feeding will start.

Duration : The length of time the feed periods will be active for.

Tick box : This button will activate a repeat function to save using multiple periods

Off time : This is the duration of time that the feeding is inactive, only used if the tick box is ticked.

Repeat this function is to save using multiple periods when sequential feeding is desired, e.g duration is set to 1h and the tick box is ticked and a off duration time set to 2h the feeding will be active for 1h and off for 2h and keep repeating this to when it is possible to move into the next feed period.

Min / Max alarm : If the Victron is being used with a blend system you can set a min / max kg alarm for each feed period, this is not used if there is not a blend system attached.

10.2 Feed Shut Down



Feed shut down is only used at the end of the crop or thin and helps with getting the feed out of the feed system and restricting the feed given, this function will take a bit of playing with to get working at its ultimate.

After the time and grow day set on the shut down the feed blender will stop, after the time has elapsed on the “auger run” the cross auger will stop then after the time has elapsed on the “pan run” it will also stop.

- On/off : Shut down function on and off.
- Day : The day that the feed shut down will be applied.
- Time : The time that the feed shut down will be applied.
- Auger run : Time off after shut down time
- Pan run : Time off after shut down time

All settings will be shared with the feed controller.

10.3 Feed Blend

BLENDING 

Grow Day	Silo 1	Silo 2	Silo 3	Silo 4
0	100	0	0	0
5	100	0	0	0
10	100	0	0	0
15	100	0	0	0
20	100	0	0	0
25	100	0	0	0
30	100	0	0	0
35	100	0	0	0
40	100	0	0	0
45	100	0	0	0
50	100	0	0	0
55	100	0	0	0
60	100	0	0	0
65	100	0	0	0

Blend Curve Used: 1

Feed Blend is the blend of up to 4 silos. All 4 silos must add up to 100%, these setting will be sent to the feed controller, it is not possible to use the same grow days more than once.

“Blend curve used” sets how many lines are being used.

13.1 Extra

<i>Extra 1</i>	<i><=></i>	<i>Set</i>	<i>On time</i>	<i>Off time</i>
<i>ACTIVE 1</i>				
<i>Or</i>				
<i>ACTIVE 2</i>				
<i>Or</i>				
<i>ACTIVE 3</i>				

Four additional extra controls to switch four additional relay outputs to be used for what ever you desire (outside lights, indicators or general control).

Use the dropdown to choose a function, choose operation $<$, $>$, $=$ and the desired set parameter, the on/off time is a cycle time in sec.

3 actives can be used at the same time for one output.

If all of those variables are met the output will be toggled.

14.1 Mortality

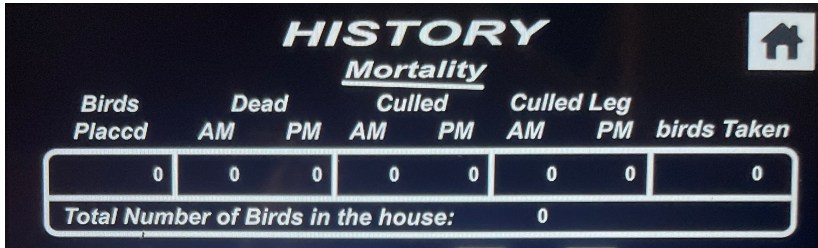

HISTORY								
<u>Mortality</u>								
<i>Birds Placcd</i>	<i>Dead</i>		<i>Culled</i>		<i>Culled Leg</i>		<i>birds Taken</i>	
	<i>AM</i>	<i>PM</i>	<i>AM</i>	<i>PM</i>	<i>AM</i>	<i>PM</i>		
0	0	0	0	0	0	0	0	
<i>Total Number of Birds in the house:</i>					0			

This keeps a record of the mortality throughout the whole crop and keeps a running total.

This will be reset back to 0 when house mode (in config) is changed from empty to full.

If using live weight for minion ventilation this should be kept accurate.

14.2 General History



HISTORY

Mortality

Birds Placcd	Dead AM	Dead PM	Culled AM	Culled PM	Culled Leg AM	Culled Leg PM	birds Taken
0	0	0	0	0	0	0	0

Total Number of Birds in the house: 0

X Axis Time: Grow day 1-7

 Graph

 Table

Y Axis 1	Y Axis 2	Y Axis 3	Y Axis 4
Temperature	Temperature	Combo Sensor	Combo Sensor
Temp Ave Max	Temp Ave Min	RH Max	RH Min
Y Axis 5	Y Axis 6	Y Axis 7	Y Axis 8
Run Times	Run Times	Run Times	Run Times
Heater P1 Run Mins	Heater P2 Run Mins	Heater S1 Run Mins	Heater S2 Run Mins

Day	Temp Ave Max	Temp Ave Min	RH Max	RH Min	Heater P1 Run	Heater P2 Run	Heater S1 Run	Heater S2 Run
2025-07-12	34.8	33.5	53.6	42.1	62	154	0	0
2025-07-13	34.6	33.0	56.9	43.8	64	115	0	0
2025-07-14	33.9	32.0	57.3	49.9	48	111	0	0
2025-07-15	33.1	31.3	61.5	51.7	126	193	0	0
2025-07-16	32.6	31.0	62.4	53.6	42	79	0	0
2025-07-17								
2025-07-18								

The history page will keep a record of what has been going on over the current 24h, last 24, grow days is 5 day increment, this can be set as “X axis time”.

Can use up to 8 Y axis, using the drop down boxes will give you a large selection of variables to choose from.

After choosing your x and y axis choose graph or table and one or the other will be displayed below.

This will be reset back to 0 when house mode (in config) is changed from empty to full.

15.1 Stir Fans

<i>STIR FANS</i>							
	<i>Temp Allocation</i>		<i>Diff Low</i>	<i>Diff High</i>	<i>Min Speed</i>	<i>Max Speed</i>	<i>Lev Off</i>
<i>Near</i>	<input checked="" type="checkbox"/>	<input type="checkbox"/>	<input checked="" type="checkbox"/>	<input type="checkbox"/>	<input type="checkbox"/>	<input type="checkbox"/>	OT1
<i>Far</i>	<input type="checkbox"/>	<input type="checkbox"/>	<input type="checkbox"/>	<input type="checkbox"/>	<input type="checkbox"/>	<input type="checkbox"/>	OT15

Stir fans control helps to maintain a constant temperature over the house by switching on/off or speed controlling the near and far fans according to the difference in temperature from one end to the other.

Up two relay outputs and two 0-10v output can be used.

- Temp allocation : Selecting what sensors are being used for that zone, there must be two zone selected as those will be the ones that will be compared and no more.
- Diff : This is the differential between the two zones if outside this set point and that zone of stir fans will be active.
- Lev off : If the ventilation level is over this set point the stir fans will be deactivated.
- Max Speed :Setting of the max speed if using a 0-10v output.
- On/off time :A cycle time can be set if desired in sec.

16.1 Configure Setup



Curve points used: how many lines are being used on the table on the left, see page 16.2.

Temp Origin: Specifying if using the set temp or curve table on the left.

Set temp: If temp curve is not being used this is the set temp that will be used.

Set min/max temp: Sets the min/max temp alarm if not using the temp curve (“Temp curve” is set to “set”)

Grow day: Sets the Current grow day.

Day Change: This is the point of the day that the controller toggles into the next grow day.

Empty house: Can be used for when the house is empty and will hold the house on that day.

Saving and reading USB see page 39.

Set Data: Setting the data.

Set time: Setting the time.

16.2 Configure Table Setup

CONFIGURE



Grow Day	Temp Curve		Alarms		RH %	Weight g
	Required Temp	Min	Max			
0	34.0	5.0	5.0	65	48	
1	34.0	5.0	5.0	65	58	
7	29.5	5.0	5.0	65	188	
14	27.0	5.0	5.0	65	490	
17	26.0	5.0	5.0	65	680	
21	24.5	5.0	5.0	6	975	
28	22.0	5.0	5.0	65	1535	
30	22.0	5.0	5.0	60	1718	
31	21.5	5.0	5.0	60	1811	
38	21.0	5.0	5.0	60	2485	
50	18.0	5.0	5.0	60	210	
55	18.0	5.0	5.0	60	220	
60	18.0	5.0	5.0	60	230	
65	18.0	5.0	5.0	60	240	
70	18.0	5.0	5.0	60	250	
75	18.0	5.0	5.0	60	260	
80	18.0	5.0	5.0	60	270	
85	18.0	5.0	5.0	60	280	
90	18.0	5.0	5.0	60	290	
95	18.0	5.0	5.0	60	300	

Temp trim: RH trim: Weight trim:

V255.255 LV4.11

Curve Points
Used..... 10

Temp Origin..... 21.4
Set Temp..... 16.4 26.4
Set Min/Max.....

Grow Day..... 33
Day Change..... 0
Empty House.....
House Number..... 7

Save To USB.....
Read From USB.....
Without Layout.....

Set Date.....
Set Time.....

The temperature curve will have to be activated at the top of the page "Temp curve" otherwise the house temperature will be as a set temperature "Set temp" and "set min/max alarm" when set to curve the temp alarm will display what the table is outputting, at the top of the page you can set how many lines of the page will be active, it is not possible to use the same grow days more than once in the curve table.

Temp curve table: is where to set the desired required temp, min/max alarm and RH, live weight in relation to the grow day.

When moving from one grow day to another will linearly move from one to the other, also applies for alarms, RH and weight.

At the bottom of the page you can trim temp, RH, weight up or down for the complete row.

16.3 Alarms

At the top of the page will display any alarm that has happened and the grow day it happened on and the time taken to reset the alarm, using the alarm reset button will reset any alarm that has occurred.

Water Alarm: is based on the consumption of water not pressure so the “time duration” must have a consumption more than the min and less that the max in relation to the grow day, typically a time duration of 20 min is used, at the bottom of the page you can choose how many curve points you used, this function will be disabled in dark periods and drinker flushing times.

Alarm Isolate: Right hand table allow the user to switch any of the alarms on or off and a min/max point for any of the gas sensors, trim will allow the user to trim any of the sensor inputs BUT before doing this insure the the reading you are getting is incorrect before trimming, it is very rare that any of the temp inputs will need to be trimmed at all.

House alarm: isolate all house alarms.

Alarm test: It is possible to create an alarm at set point in a day/week for a set duration for test purpose, this is recommended to confirm that all alarm equipment is operating correctly.

Alarms

Grow Day	Date & Time	Reset Time	Reset By	Alarm Log
30	2025-06-23 08:57	2025-06-26 20:41	Admin	Temperature 3 low
27	2025-06-20 15:24	2025-06-26 20:41	Admin	Temperature 3 high
26	2025-06-19 17:28	2025-06-26 20:41	Admin	Temperature 1 high
26	2025-06-19 15:32	2025-06-26 20:41	Admin	Water low
26	2025-06-19 15:12	2025-06-19 15:12		Power up
25	2025-06-18 17:45	2025-06-19 15:12	ECU	Temperature 3 high
25	2025-06-18 17:43	2025-06-19 15:12	ECU	Temperature 1 high
25	2025-06-18 09:15	2025-06-19 15:12	ECU	Water low

Water Alarms

Grow Day	Timer Duration	Min	Max	Trim
0	20	0	100	
5	20	1	100	
10	20	10	200	
15	20	15	300	
20	20	15	400	
25	20	40	500	
30	20	48	600	
35	20	48	55	
40	20	48	55	
45	20	48	55	

Alarm Isolation

Temp 1.....	ON	0.0
Temp 2.....	OFF	0.0
Temp 3.....	ON	0.0
Temp 4.....	OFF	0.0
Temp 5.....	OFF	0.0
Temp 6.....	OFF	0.0
RH.....	ON	10.0
RH Min.....		0.0
RH Max.....		98.0
CO2.....	ON	200
CO2 Min....		0
CO2 Max....		4500
NH3.....	OFF	0
NH3 Min....		0
NH3 Max....		1000
Aux.....	OFF	
Feed.....	OFF	

Curve Points Used..... 7
 Alarm Test Duration..... 10:00
 Alarm Test Time.....
 Alarm Test Day..... Off House Alarm..... ON

16.4 Saving To USB

A normal pen drive can be used, but must have been formatted before use, some times it will need a moment to recognise that the drive is there, it will display USB in green on the home page to show that the pen drive has been seen.

When looking at the back side of the display, looking around the bottom side you will see a selection of usb's that can be used, anyone of them can be plugged in, some installations will come with an extension to make it more convenient to plug in.

In Config in the table at the top of the page use "save to usb" this will save all setting's to the pen drive.

"Read from usb" will retract all setting's, this should only be done on installation.

"Without layout usb" this will retract all setting's but not any of the setup setting's e.g I/O locations, this can be used for every day use.

16.5 Testing I/O

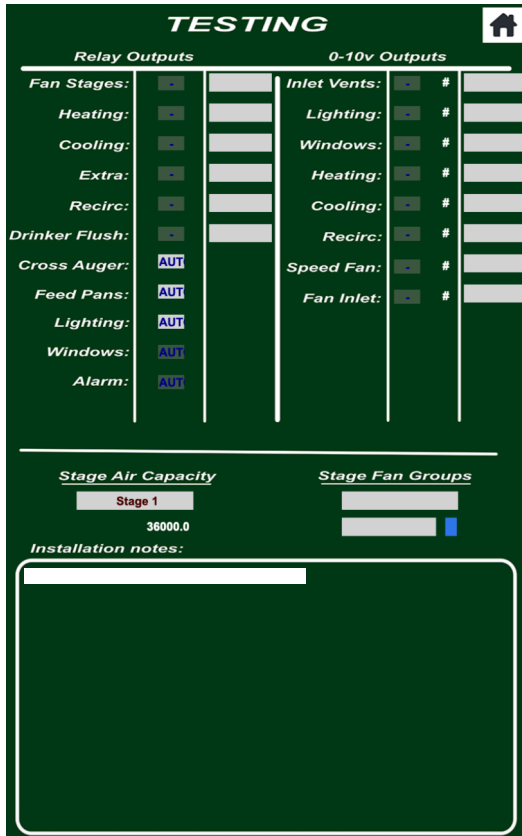

Testing allows you to test all of the outputs by clicking on the desired output and toggling that output from automatic, off and on.

0-10v outputs can be set to any percentage output.

Stage Air capacity: set the air capacity of each output.

Stage fan groups: if you have each fan wired back separately you can set the fan groups here.

If a fault occur try it in manual to see if it will work, if not you have a hardware fault, if it does you have a setting incorrect.

All outputs will returned back to automatic after leaving page.

“Installation notes” can document any quirk of the installation or note on when the battery should be changed.

16.5 Setting I/O

Relay Cards Setup

	Device	Device Number	No / Nc	
1	Stage Fan	1	NO	
2	Stage Fan	2	NO	
3	Stage Fan	3	NO	
4	Stage Fan	4	NO	
5	Stage Fan	5	NO	
6	Stage Fan	6	NO	
Card2				
7	Stage Fan	7	NO	
8	Stage Fan	8	NO	
9	Stage Fan	9	NO	
10	Stage Fan	10	NO	
11	Not Used		NO	
12	Not Used		NO	
Card3				
13	Lighting	1	NO	
14	Feeding	Cross Aug	NO	
15	Feeding	Pans	NO	
16	Heating	P1	NO	
17	Heating	P2	NO	
18	Heating	S1	NO	
Card4				
19	Heating	S2	NO	
20	Recirc	1(Near)	NO	
21	Cooling	1	NO	
22	Not Used		NO	
23	Not Used		NO	
24	Not Used		NO	
Card5				
25	Not Used		NO	
26	Not Used		NO	
27	Not Used		NO	
28	Not Used		NO	
29	Not Used		NO	
30	Not Used		NO	
Card6				
31	Not Used		NO	
32	Not Used		NO	
33	Not Used		NO	
34	Not Used		NO	
35	Not Used		NO	
36	Not Used		NO	

Digital Inputs

For setting multiplier NOT I/O location

Water.....	1
Gas.....	1
Electric.....	1
Aux Alarm....	N,O

Sensor Inputs

Temp 1..	WIRED
Temp 2..	WIRED
Temp 3..	WIRED
Temp 4..	UNUSEC
Temp 5..	UNUSEC
Temp 6..	WIRED
Temp 7..	UNUSEC
Temp 8..	UNUSEC
Temp 9..	UNUSEC
Temp10..	UNUSEC
Combo.....	USED
OutSide.....	USED

0-10v I/O Location

Device	Min	Max
1 Vent 1	0.0	10.0
2 Lights 1	6.5	10.0
3 Lights 2	6.5	10.0
4 Recirc 1	0.0	10.0
5 Not Used	0.0	10.0
6 Not Used	0.0	10.0
7 Not Used	0.0	10.0
8 Not Used	0.0	10.0
9 Not Used	0.0	10.0
10 Not Used	0.0	10.0
11 Not Used	0.0	10.0
12 Not Used	0.0	10.0

Network Settings

Cloud UID:
IPAddress:
Connect:

Use this screen to define the devices connected to the controller, this should only be accessed by a competent person.

Use the table in 3.6 to help locate all of the I/O.

Sensor inputs have a fixed layout but you can be set as wired or wireless.

If wireless see manual for paring sensor to Victron.

Setting the analog outputs and there voltage range and direction.

Network setting for connecting to the cloud, see page next page.

Net Remote Access

For setting up a new cloud remote access insure all wiring is in place and has been tested with cable tester and then it is possible to check that the Victron has a IP address by going to Menu - setup at bottom of page.

Go to www.victron-manager.co.uk setup a new farm manager, create a username and password that you can remember, your name, this is to setup your account not the farm at this point, when you sign up you will receive an email, click on the link to confirm who you are.

When you have signed in you will see this page:

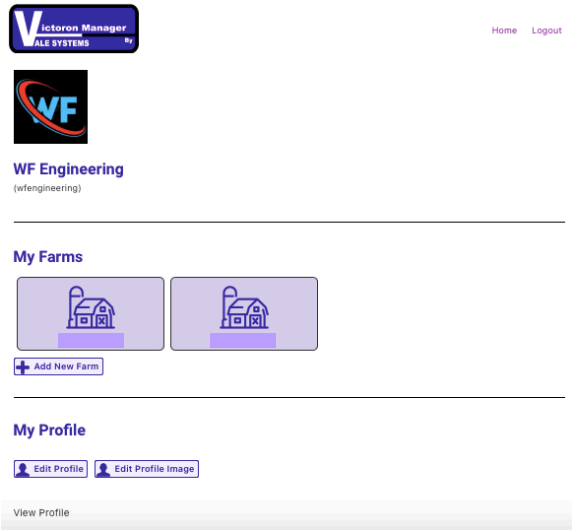

To add a farm click on + add new farm, give the farm a name and address, add a house and give it a name/number and repeat as many times you need (It is possible to have more than one farm in one account) when the house has been created it will create a cloud ID, with this it will need to be put into the Victron, go to Menu - setup & test - net and enter the cloud ID and click on Tigger, there will be a different ID for every Victron.

Net Remote Access

Sharing farms with other users click on the farm you would like to share at the bottom of the page it will show who can view this farm:

Farm members

Can

Edit



wfengineering



(Farm Admin)

Click on show member admin options enter the email of the user you would like to add to your farm and click + add user to this farm, after this you will be asked if this user is view only or full access.

It is possible to add or remove any users or editing this view only to full access.

Notes

